

CUSTOMER REFERENCE DRAWING

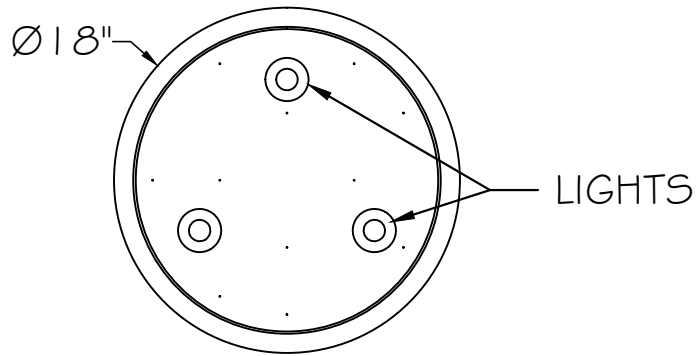

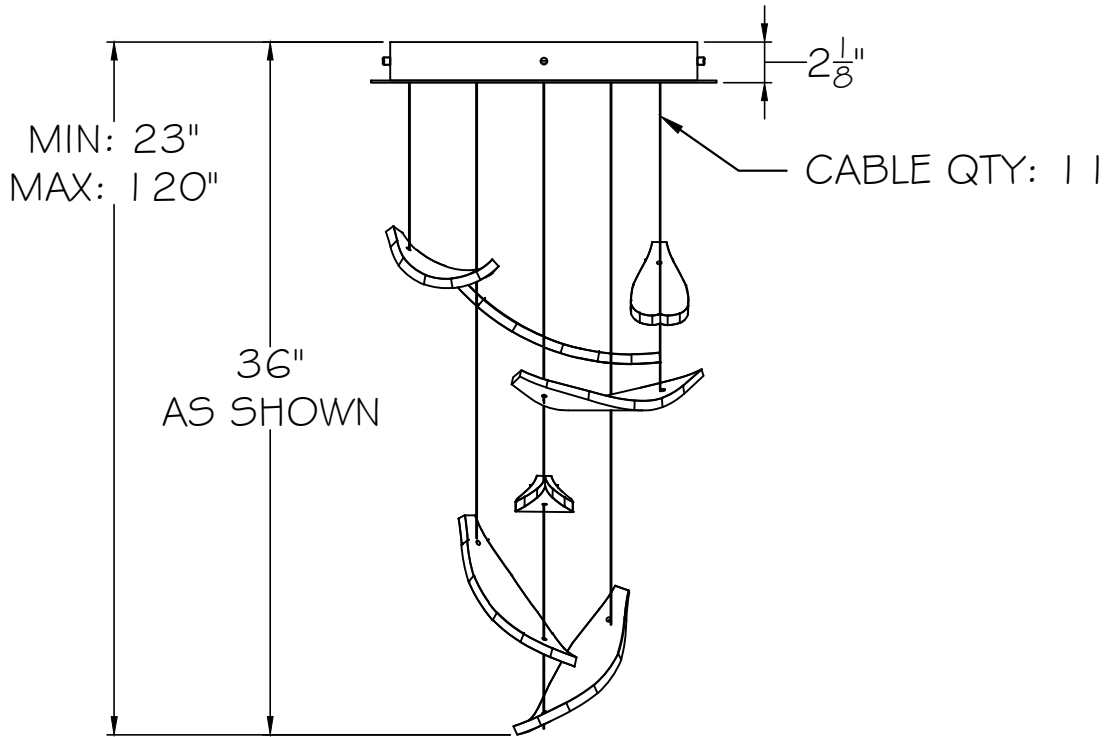



TOP VIEW

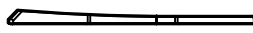
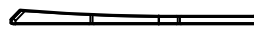
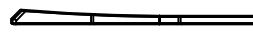

FRONT VIEW

THUMBNAIL IMAGES OF STYLE OPTIONS:

<p>-111 SILVER -211 GOLD</p>  <p>GLASS PLUME W/ DICHRO (X7)</p>	<p>-121 SILVER -221 GOLD</p>  <p>GLASS PLUME NO DICHRO (X7)</p>	<p>-131 SILVER -231 GOLD</p>  <p>GLASS SPIRE CLEAR (X10)</p>	<p>-141 SILVER -241 GOLD</p>  <p>GLASS SPIRE BLACK (X10)</p>	<p>-151 SILVER -251 GOLD</p>  <p>GLASS SPIRE METEORITE (X10)</p>
<p>-161 SILVER -261 GOLD</p>  <p>FROZEN PAGES (FRIT) (X7)</p>	<p>-171 SILVER -271 GOLD</p>  <p>BLANK PAGES (WHITE) (X7)</p>			



This drawing, specifications and the product depicted are the exclusive property of Fine Art Handcrafted Lighting®. In compliance with US copyright and patent requirements, notice is hereby given that this document and the product depicted shall not be copied, altered or used in any manner without the expressed written consent of Fine Art Handcrafted Lighting®.

www.finearthl.com

Tel:(305) 821-3850  
FINE ART LAMPS®

Fax:(305) 513-5736

STYLE NUMBER:

895640

DATE:

10/13/2020

# INSTRUCTIONS for PLUMES (Dichro & White)

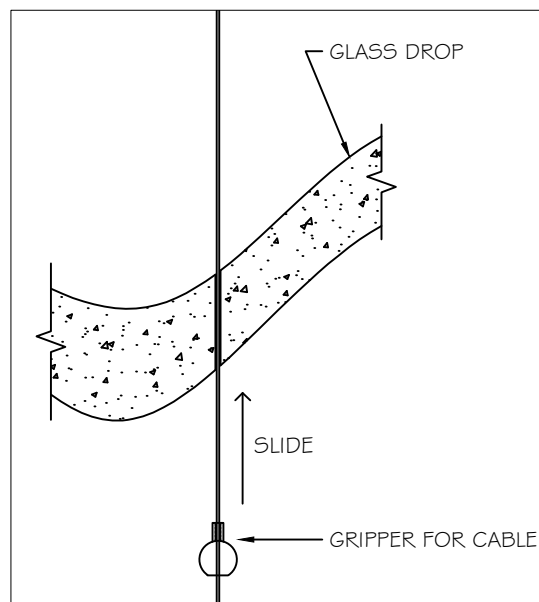
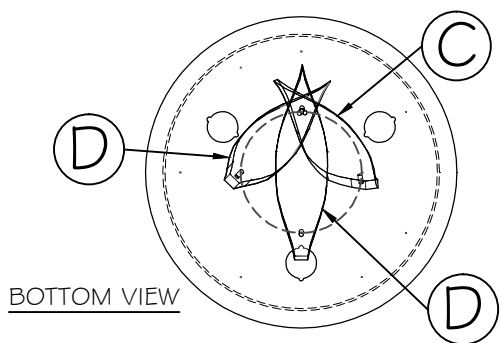
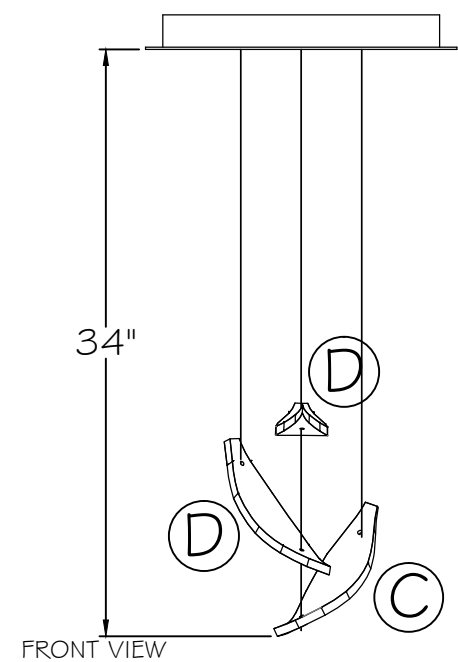
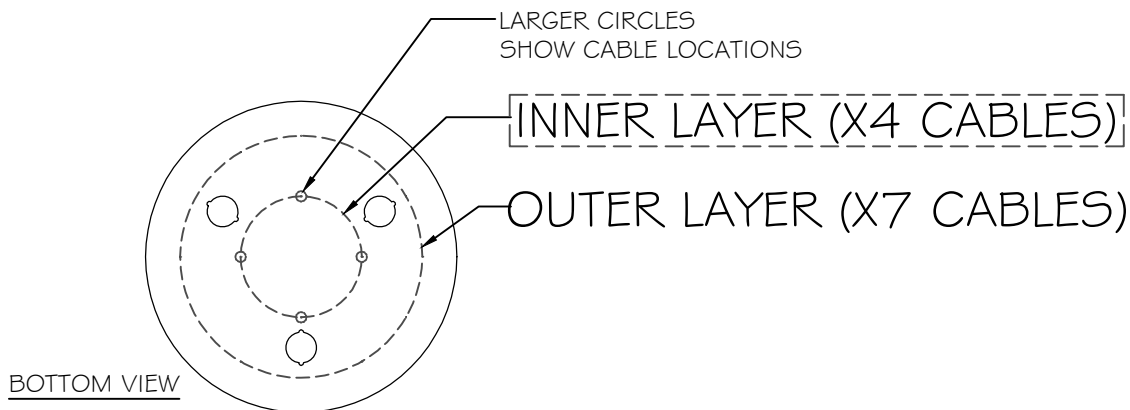

## INNER LAYER

GLASS TYPE	QUANTITY
TYPE A	0
TYPE B	0
TYPE C	1
TYPE D	2

- INNER LAYER OF GLASSES TO BE INSTALLED FIRST.
- GATHER ALL OTHER CABLES TO EASILY ACCESS LAYER TO BE WORKED ON
- LETTERS IN CIRCLES ON DIAGRAM INDICATE GLASS TYPE THAT CORRESPONDS TO STICKERS ON GLASS
- START SLIDING GLASSES UP INTO POSITION AS SHOWN ON FRONT VIEW, STARTING FROM TOP TO BOTTOM
- SLIDE GRIPPER UP TO HOLD POSITION OF GLASS
- NOTE: MULTIPLE GLASSES MAY USE THE SAME CABLES

STYLE(S) #: 895640-111 -211 -121 -221



This drawing, specifications and the product depicted are the exclusive property of Fine Art Handcrafted Lighting®. In compliance with US copyright and patent requirements, notice is hereby given that this document and the product depicted shall not be copied, altered or used in any manner without the expressed written consent of Fine Art Handcrafted Lighting®.

www.finearthl.com

Tel:(305) 821-3850  
FINE ART LAMPS®

Fax:(305) 513-5736

INSTRUCTION #:

00791412

SHEET

1 / 3

INSTRUCTIONS for PLUMES (Dichro & White)

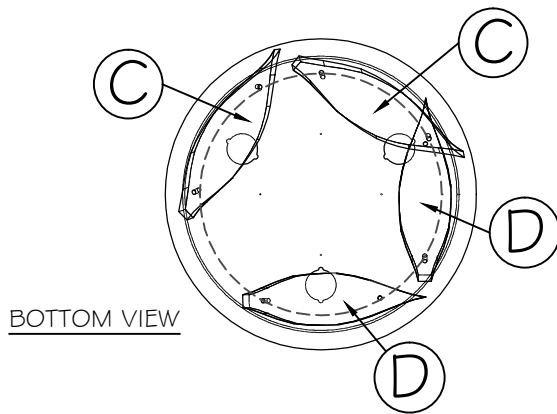
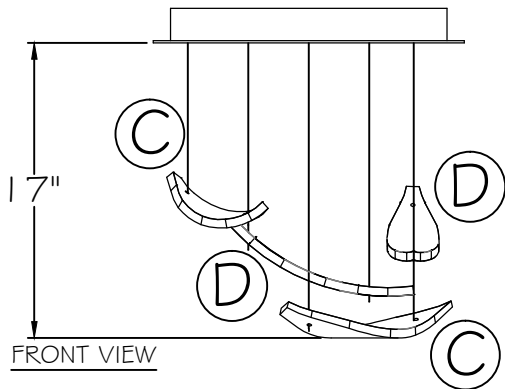
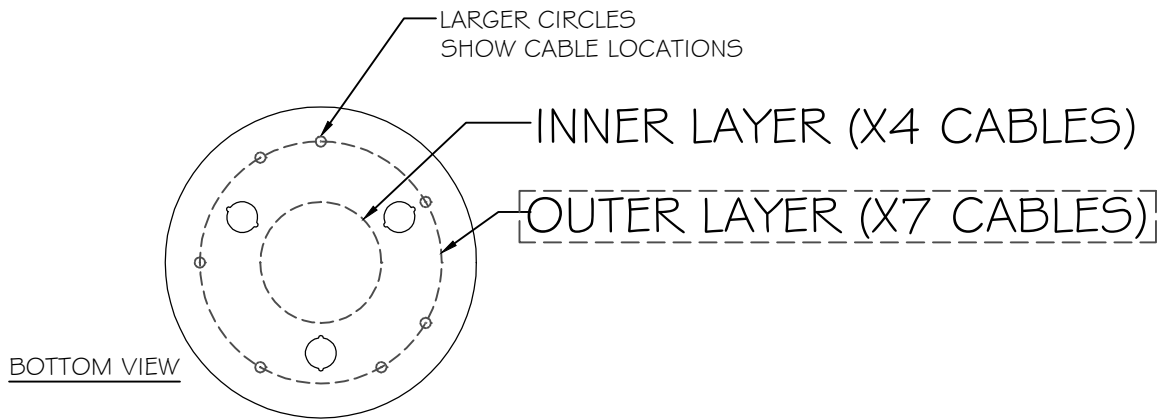

OUTER LAYER	
GLASS TYPE	QUANTITY
TYPE A	0
TYPE B	0
TYPE C	2
TYPE D	2

- OUTER LAYER OF GLASSES TO BE INSTALLED LAST.
- START SLIDING GLASSES UP INTO POSITION AS SHOWN ON FRONT VIEW, STARTING FROM TOP TO BOTTOM
- SLIDE GRIPPER UP TO HOLD POSITION OF GLASS
- NOTE: MULTIPLE GLASSES MAY USE THE SAME CABLES

STYLE(S) #: 895640-111 -211 -121 -221



This drawing, specifications and the product depicted are the exclusive property of Fine Art Handcrafted Lighting®. In compliance with US copyright and patent requirements, notice is hereby given that this document and the product depicted shall not be copied, altered or used in any manner without the expressed written consent of Fine Art Handcrafted Lighting®.

www.finearthl.com Tel:(305) 821-3850 Fax:(305) 513-5736  
FINE ART LAMPS®

INSTRUCTION #:  
00791412

SHEET  
2 / 3

# INSTRUCTIONS for PLUMES (Dichro & White)

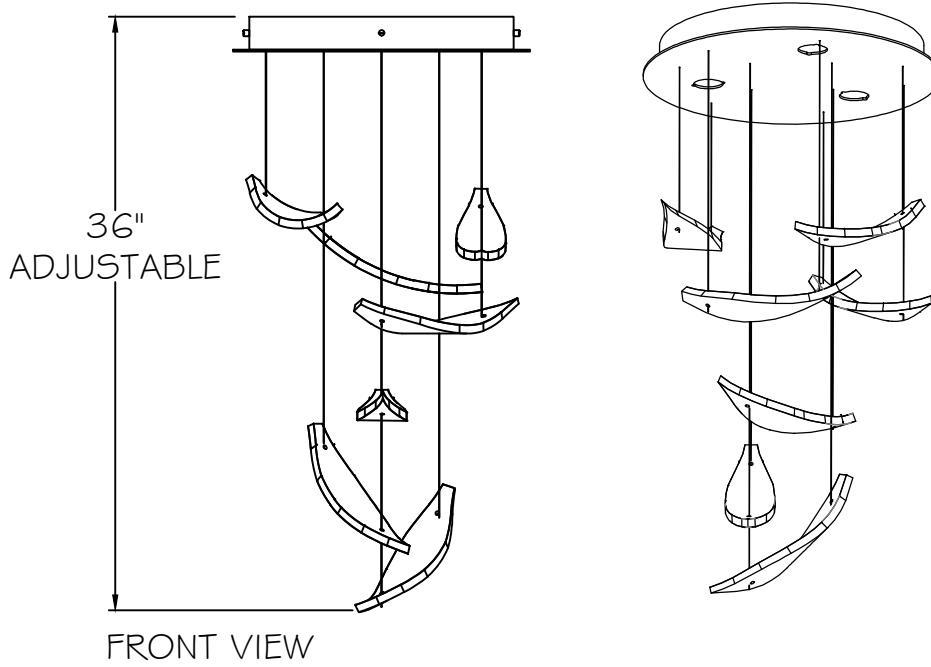

- ONCE ALL GLASSES ARE INSTALLED AND FINAL GLASS POSITION IS ACHIEVED, ENSURE TO CUT EXCESS CABLES UP TO HARDWARE OF LOWEST GLASSES. REFERENCE INSTALLATION INSTRUCTIONS.

STYLE(S) #: 895640-111 -211 -121 -221

**FINE  
ART**  
HANDCRAFTED LIGHTING

This drawing, specifications and the product depicted are the exclusive property of Fine Art Handcrafted Lighting®. In compliance with US copyright and patent requirements, notice is hereby given that this document and the product depicted shall not be copied, altered or used in any manner without the expressed written consent of Fine Art Handcrafted Lighting®.

www.finearthl.com

Tel:(305) 821-3850  
FINE ART LAMPS®

Fax:(305) 513-5736

INSTRUCTION #:

00791412

SHEET

3 / 3

# INSTRUCTIONS for SPIRES (Meteorite, Crystal & Ebony)

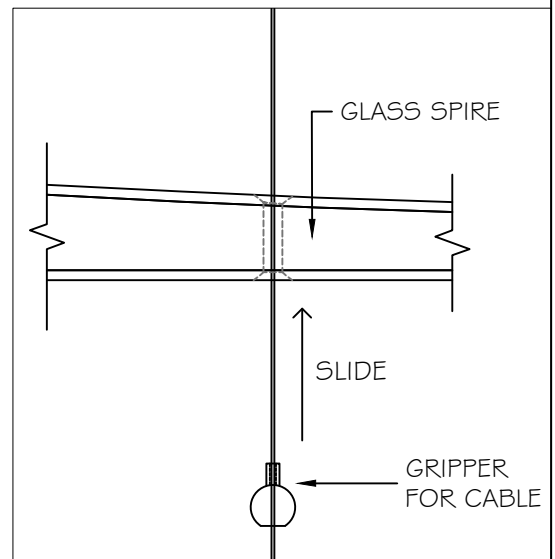
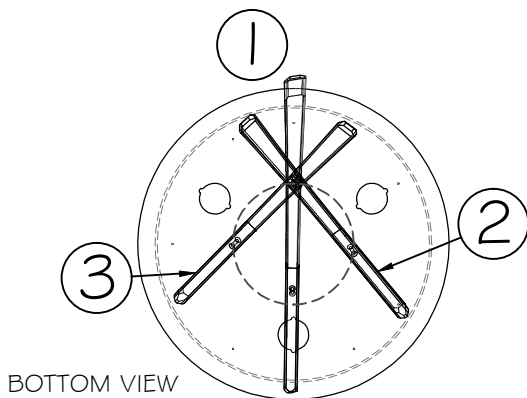
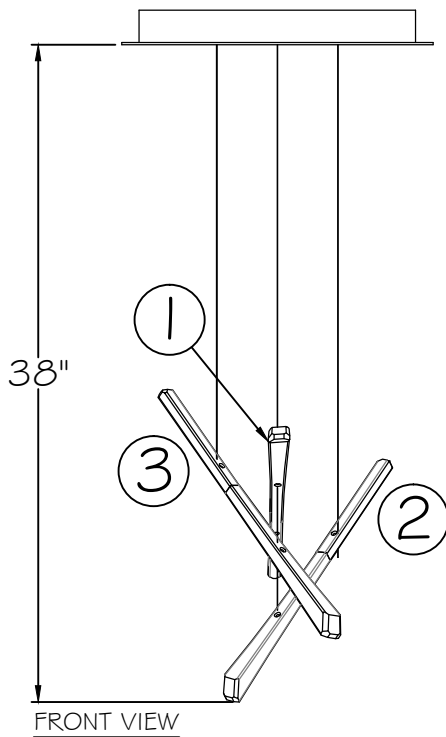
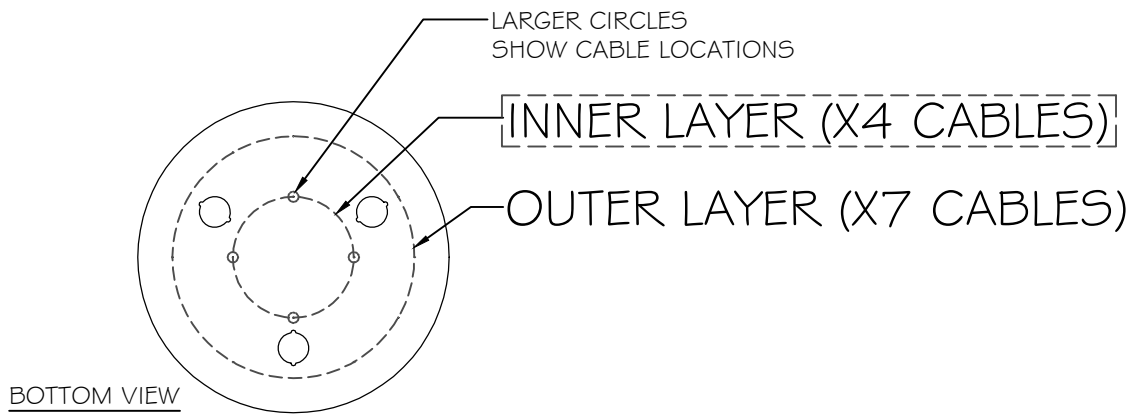

- INNER LAYER OF GLASSES TO BE INSTALLED FIRST.
- GATHER ALL OTHER CABLES TO EASILY ACCESS LAYER TO BE WORKED ON
- START SLIDING GLASSES UP INTO POSITION AS SHOWN ON FRONT VIEW, STARTING FROM TOP TO BOTTOM
- SLIDE GRIPPER UP TO HOLD POSITION OF GLASS
- NOTE: MULTIPLE GLASSES MAY USE THE SAME CABLES

STYLE(S) #: 895640-131 -231 -141 -241 -151 -251

**FINE  
ART**  
HANDCRAFTED LIGHTING

This drawing, specifications and the product depicted are the exclusive property of Fine Art Handcrafted Lighting®. In compliance with US copyright and patent requirements, notice is hereby given that this document and the product depicted shall not be copied, altered or used in any manner without the expressed written consent of Fine Art Handcrafted Lighting®.

www.finearthl.com

Tel:(305) 821-3850  
FINE ART LAMPS®

Fax:(305) 513-5736

INSTRUCTION #:

00791413

SHEET

1 / 3

# INSTRUCTIONS for SPIRES (Meteorite, Crystal & Ebony)

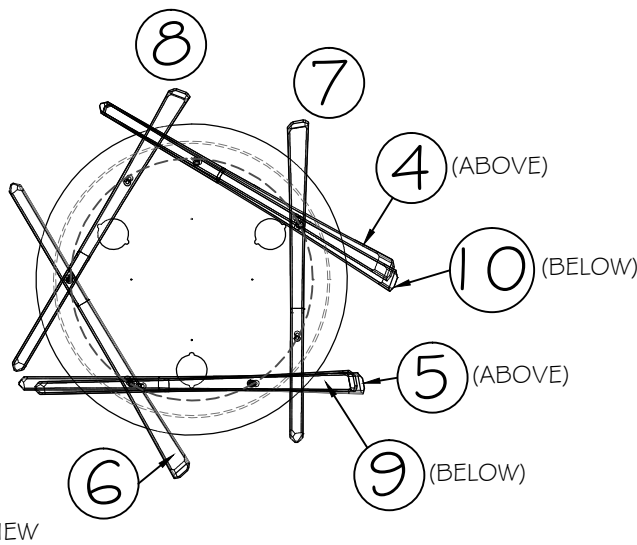
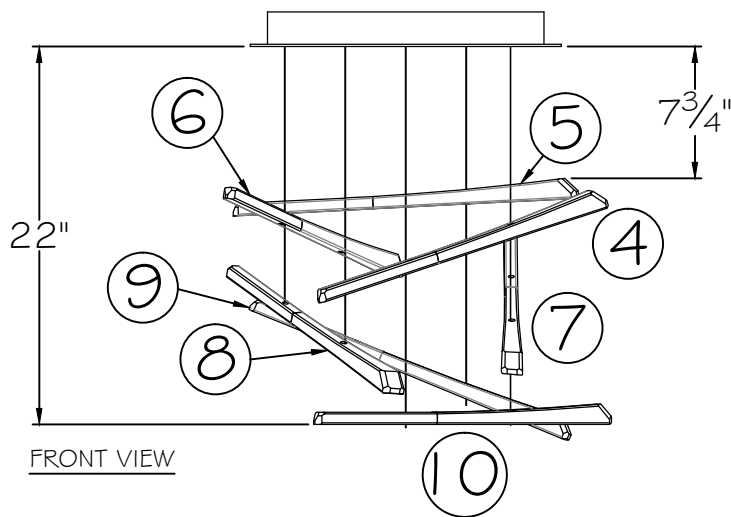
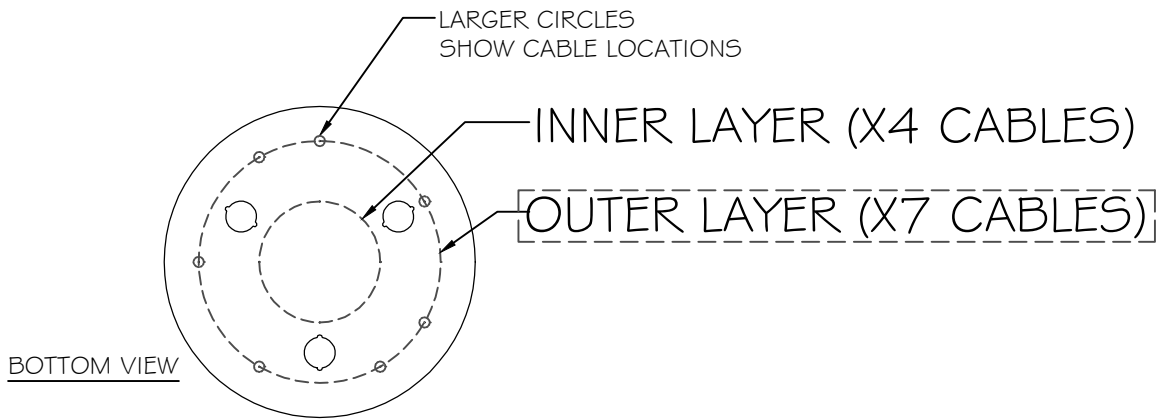

- OUTER LAYER OF GLASSES TO BE INSTALLED LAST.
- START SLIDING GLASSES UP INTO POSITION AS SHOWN ON FRONT VIEW, STARTING FROM TOP TO BOTTOM
- SLIDE GRIPPER UP TO HOLD POSITION OF GLASS
- NOTE: MULTIPLE GLASSES MAY USE THE SAME CABLES

STYLE(S) #: 895640-131 -231 -141 -241 -151 -251



This drawing, specifications and the product depicted are the exclusive property of Fine Art Handcrafted Lighting®. In compliance with US copyright and patent requirements, notice is hereby given that this document and the product depicted shall not be copied, altered or used in any manner without the expressed written consent of Fine Art Handcrafted Lighting®.

www.finearthl.com

Tel:(305) 821-3850  
FINE ART LAMPS®

Fax:(305) 513-5736

INSTRUCTION #:

00791413

SHEET

2 / 3

# INSTRUCTIONS for SPIRES (Meteorite, Crystal & Ebony)

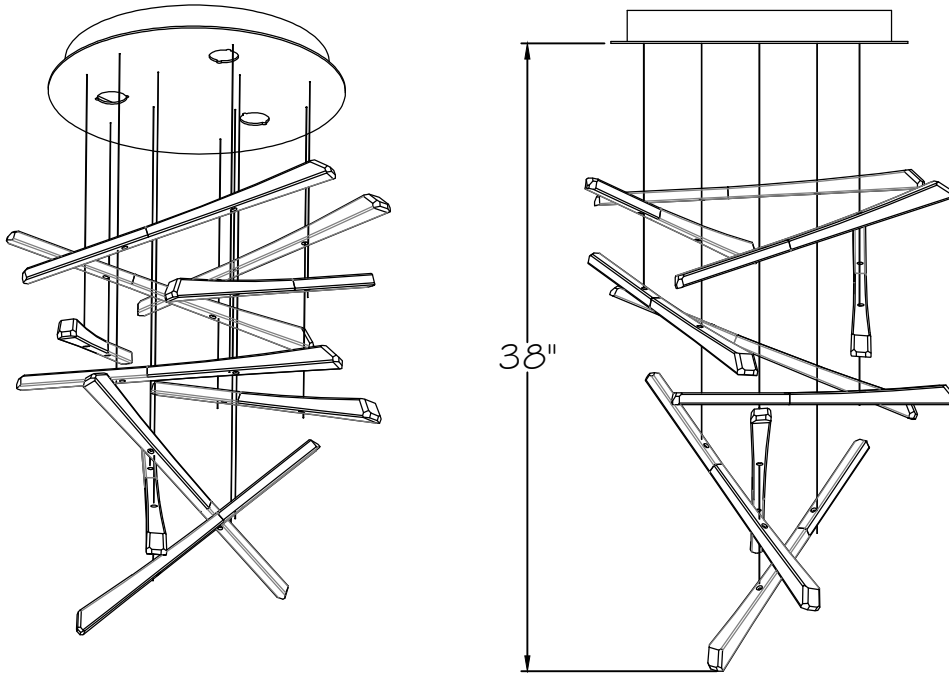

- ONCE ALL GLASSES ARE INSTALLED AND FINAL GLASS POSITION IS ACHIEVED, ENSURE TO CUT EXCESS CABLES UP TO HARDWARE OF LOWEST GLASSES. REFERENCE INSTALLATION INSTRUCTIONS.

STYLE(S) #: 895640-131 -231 -141 -241 -151 -251



This drawing, specifications and the product depicted are the exclusive property of Fine Art Handcrafted Lighting®. In compliance with US copyright and patent requirements, notice is hereby given that this document and the product depicted shall not be copied, altered or used in any manner without the expressed written consent of Fine Art Handcrafted Lighting®.

[www.finearthl.com](http://www.finearthl.com)

Tel:(305) 821-3850  
FINE ART LAMPS®

Fax:(305) 513-5736

INSTRUCTION #:

00791413

SHEET

3 / 3

INSTRUCTIONS for PAGES (Blank & Frozen)

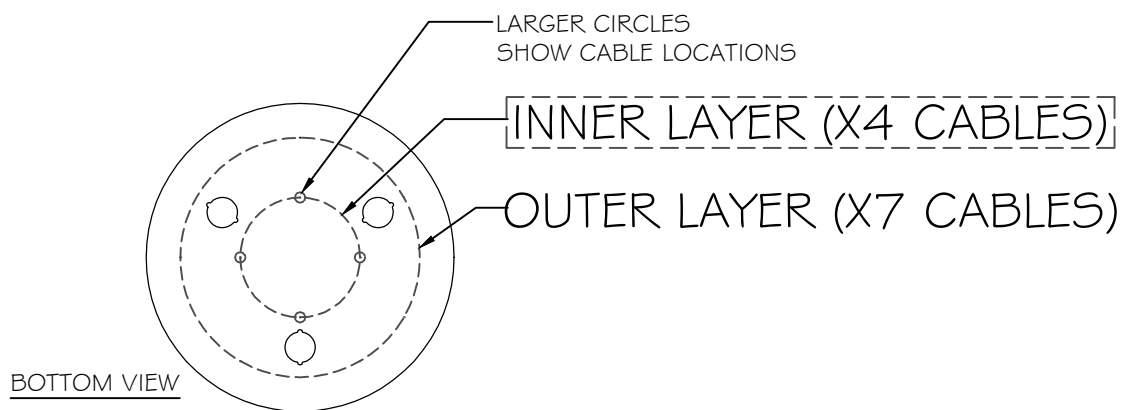

BOTTOM VIEW

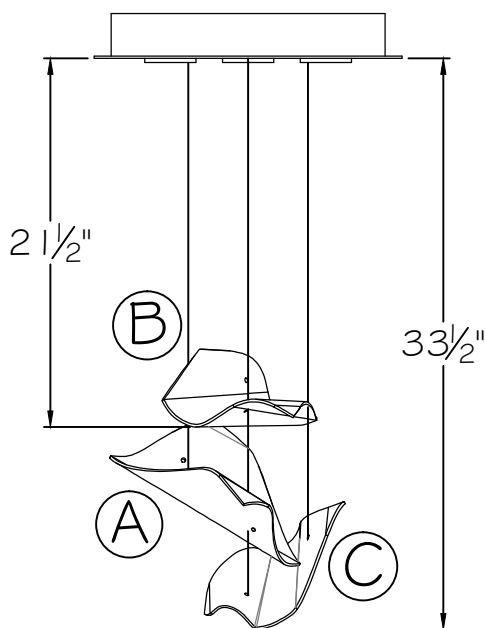

FRONT VIEW

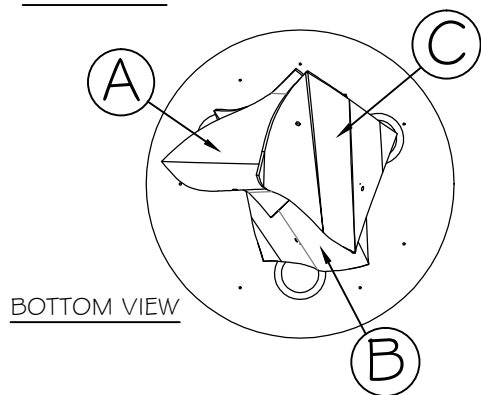

BOTTOM VIEW

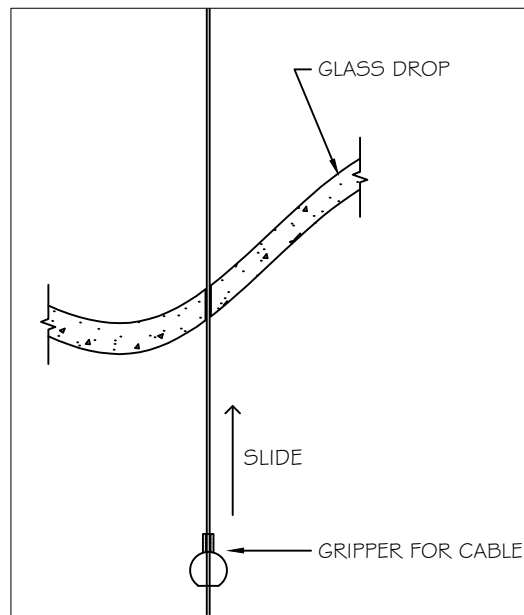

INNER LAYER

GLASS TYPE	QUANTITY
TYPE A	1
TYPE B	1
TYPE C	1

- INNER LAYER OF GLASSES TO BE INSTALLED FIRST.
- GATHER ALL OTHER CABLES TO EASILY ACCESS LAYER TO BE WORKED ON
- LETTERS IN CIRCLES ON DIAGRAM INDICATE GLASS TYPE THAT CORRESPONDS TO STICKERS ON GLASS
- START SLIDING GLASSES UP INTO POSITION AS SHOWN ON FRONT VIEW, STARTING FROM TOP TO BOTTOM
- SLIDE GRIPPER UP TO HOLD POSITION OF GLASS
- NOTE: MULTIPLE GLASSES MAY USE THE SAME CABLES

STYLE(S) #: 895640-161 -261 -171 -271



This drawing, specifications and the product depicted are the exclusive property of Fine Art Handcrafted Lighting®. In compliance with US copyright and patent requirements, notice is hereby given that this document and the product depicted shall not be copied, altered or used in any manner without the expressed written consent of Fine Art Handcrafted Lighting®.

www.finearthl.com Tel:(305) 821-3850 Fax:(305) 513-5736  
FINE ART LAMPS®

INSTRUCTION #:  
00791496

SHEET  
1 / 3



INSTRUCTIONS for PAGES (Blank & Frozen)

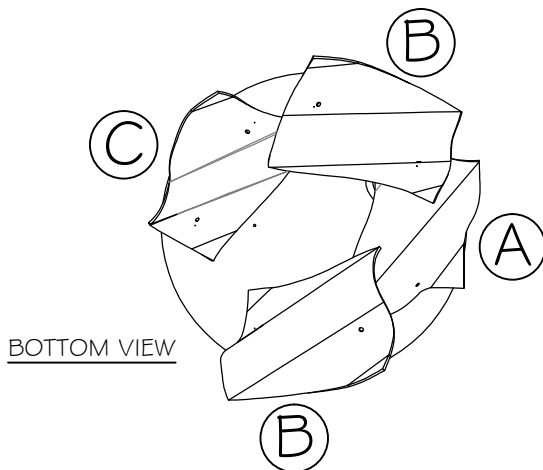
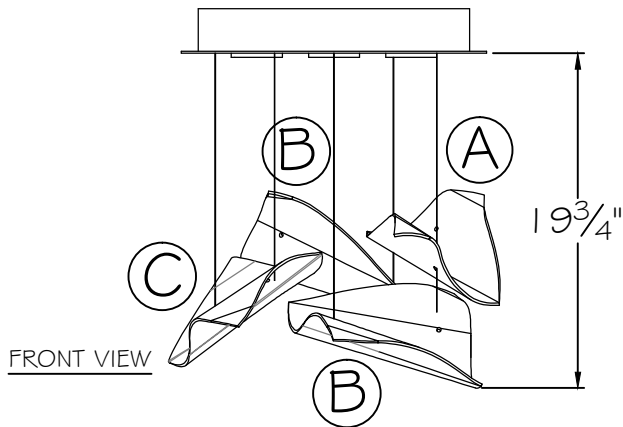
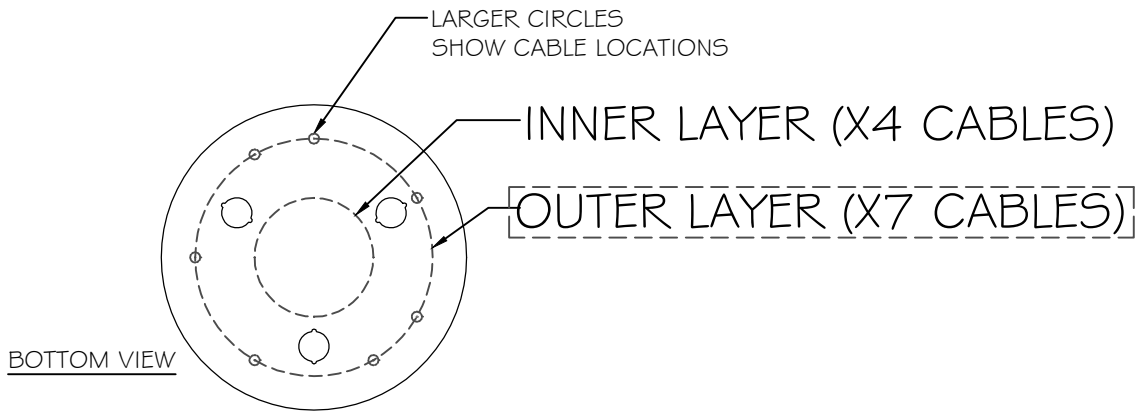

OUTER LAYER	
GLASS TYPE	QUANTITY
TYPE A	1
TYPE B	2
TYPE C	1

- OUTER LAYER OF GLASSES TO BE INSTALLED LAST.  
 - START SLIDING GLASSES UP INTO POSITION AS SHOWN ON FRONT VIEW, STARTING FROM TOP TO BOTTOM  
 - SLIDE GRIPPER UP TO HOLD POSITION OF GLASS  
 - NOTE: MULTIPLE GLASSES MAY USE THE SAME CABLES

STYLE(S) #: 895640-161 -261 -171 -271



This drawing, specifications and the product depicted are the exclusive property of Fine Art Handcrafted Lighting®. In compliance with US copyright and patent requirements, notice is hereby given that this document and the product depicted shall not be copied, altered or used in any manner without the expressed written consent of Fine Art Handcrafted Lighting®.

www.finearthl.com Tel:(305) 821-3850 Fax:(305) 513-5736  
FINE ART LAMPS®

INSTRUCTION #:  
00791496

SHEET  
2 / 3

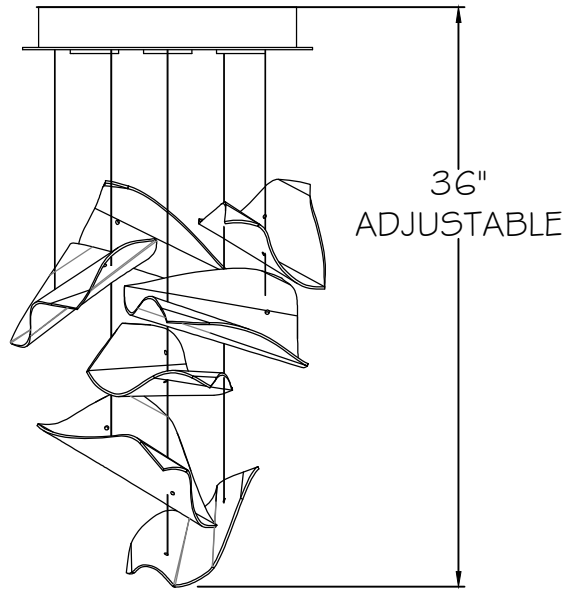
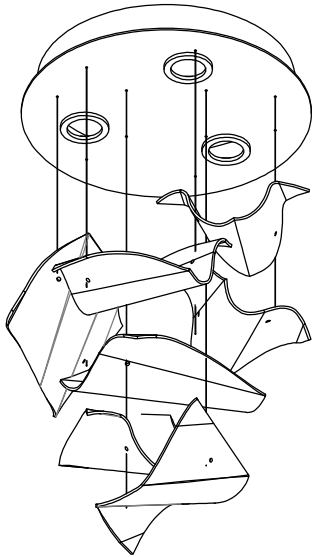

FRONT VIEW

- ONCE ALL GLASSES ARE INSTALLED AND FINAL GLASS POSITION IS ACHIEVED, ENSURE TO CUT EXCESS CABLES UP TO HARDWARE OF LOWEST GLASSES. REFERENCE INSTALLATION INSTRUCTIONS.

STYLE(S) #: 895640-161 -261 -171 -271



This drawing, specifications and the product depicted are the exclusive property of Fine Art Handcrafted Lighting®. In compliance with US copyright and patent requirements, notice is hereby given that this document and the product depicted shall not be copied, altered or used in any manner without the expressed written consent of Fine Art Handcrafted Lighting®.

[www.finearthl.com](http://www.finearthl.com)

Tel:(305) 821-3850  
FINE ART LAMPS®

Fax:(305) 513-5736

INSTRUCTION #:

00791496

SHEET

3 / 3